

# Square Shaft Specification Sheet

Please see reverse for other configurations and information



908 Jeffco Executive Drive  
Imperial, MO 63052-1700  
Ph: (636) 741-5700  
Fax: (636) 741-5701

**SHAFTS MATERIAL:**

- ALUMINUM #6061
- CARBON STEEL #1018
- STAINLESS STEEL #303
- STAINLESS STEEL #316

**SIZE:**

- 5/8" SQUARE
- 1" SQUARE
- 1.5" SQUARE
- 2.5" SQUARE
- 3.5" SQUARE

**NO. REQUIRED:**

DRIVE \_\_\_\_ IDLE \_\_\_\_

**CONTACT NAME:**

**CUSTOMER:**

**DATE:**

**DRIVE SPROCKETS:**

SERIES \_\_\_\_\_ NO. PER SHAFT \_\_\_\_\_

PITCH DIAMETER \_\_\_\_\_

**IDLE SPROCKETS:**

SERIES \_\_\_\_\_ NO. PER SHAFT \_\_\_\_\_

PITCH DIAMETER \_\_\_\_\_

**RETAINER RING GROOVES:**

STD.  NONE

MULTIPLE \_\_\_\_\_

**CHAMFER**  YES  NO

(NOTE: SPROCKETS FOR SERIES 200, 400 & NON EZ CLEAN 800 REQUIRE CHAMFERS)

**TOLERANCES**

(UNLESS OTHERWISE SPECIFIED)

- A) OVERALL LENGTH  $\leq 48" \pm 0.061$   
 $\geq 48" \pm 0.125$
- B) JOURNAL & STEPDOWN  $-0.0005$   
 $-0.003$
- C) KEYWAY WIDTHS  $+0.003$   
 $-0.000$
- D) OTHER  $\pm 0.031$

**SURFACE FINISHES**

- A) JOURNAL & STEPDOWN  
JOURNAL DIAMETER  
63 MICRINOCHES
- B) OTHER MACHINED SURFACES  
125 MICRINOCHES

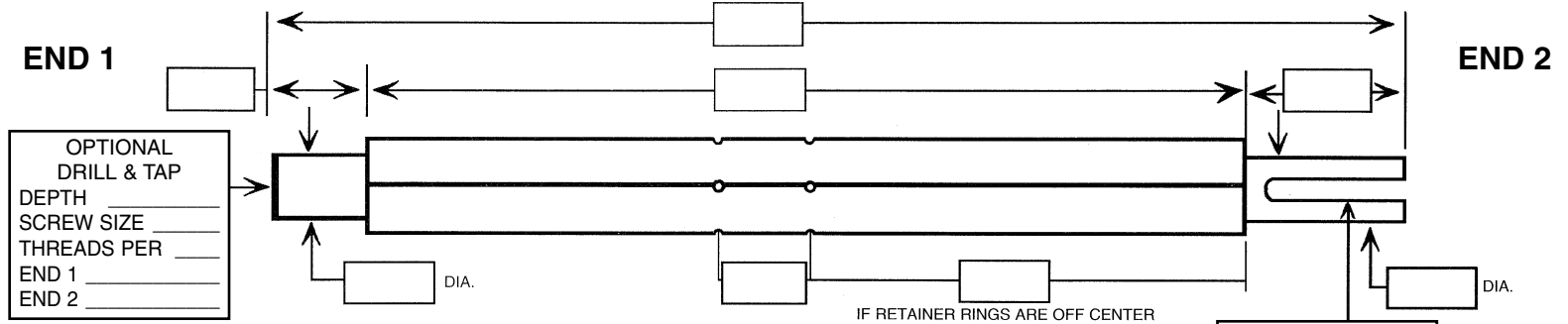

**DRIVE SHAFT**

**IDLE SHAFT**

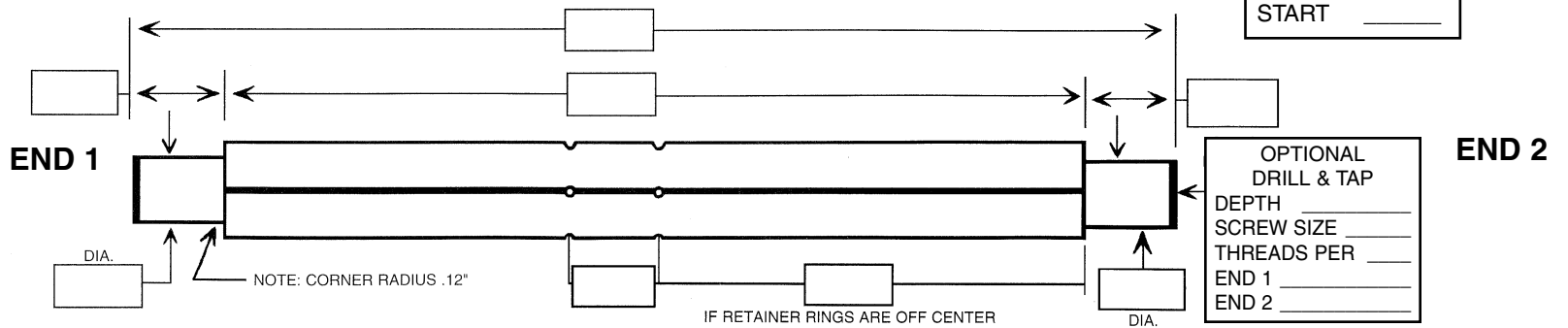

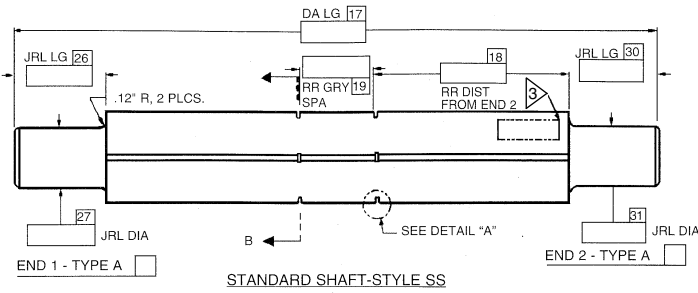

STANDARD SHAFT-STYLE SS

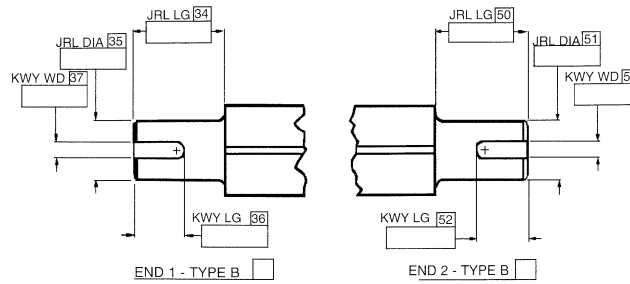

KEYWAY ON JOURNAL

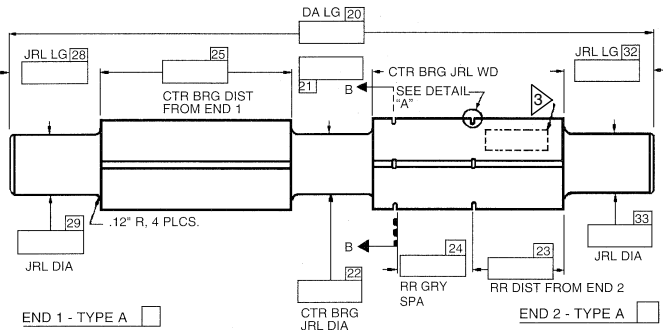

CENTER BEARING SUPPORT SHAFT-STYLE CB

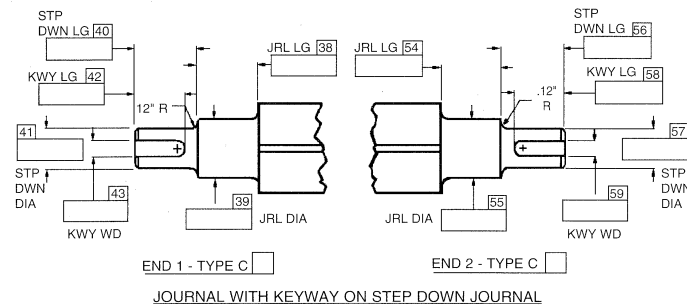

JOURNAL WITH KEYWAY ON STEP DOWN JOURNAL

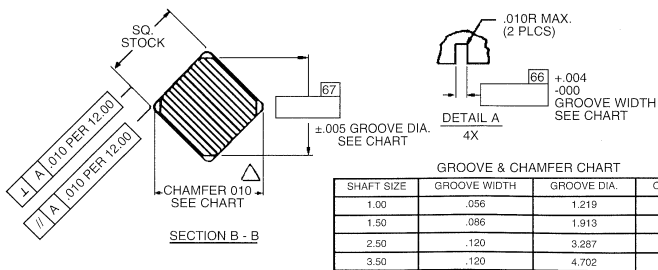

GROOVE & CHAMFER CHART

SHAFT SIZE	GROOVE WIDTH	GROOVE DIA.	CHAMFER
1.00	.056	1.219	1.314
1.50	.086	1.913	2.022
2.50	.120	3.287	3.436
3.50	.120	4.702	4.850

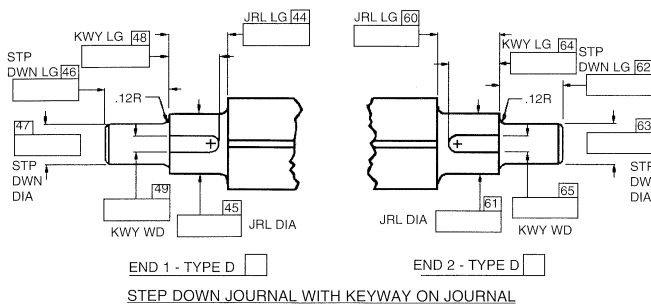

STEP DOWN JOURNAL WITH KEYWAY ON JOURNAL

NOTES:

- 1) SELECT APPROPRIATE SHAFT SIZE, MATERIAL & END CONFIGURATION BY CHECKING BOXES & FILLING IN BLANKS. CROSS OUT VIEWS NOT USED. ONLY 1 SHAFT MAY BE SPECIFIED PER DRAWING.
- 2) FILL IN APPROPRIATE DIMENSIONS TO 4 DECIMAL PLACES.
- 3) STEEL STAMP SALES ORDER NUMBER IN 0.25" CHARACTERS APPROXIMATELY WHERE SHOWN.
- 4) UNLESS OTHERWISE SPECIFIED, METRIC KEYWAYS TO USE ISO STANDARDS.
- 5) UNLESS OTHERWISE SPECIFIED, KEYWAYS ARE FOR PARALLEL SQUARE KEYS. KEYWAY DEPTH TO BE DETERMINED BY JOURNAL DIAMETER & WIDTH SPECIFIED PER ANSI B17.1 - 1967, R 1973 (REF INTRALOX DWG #1320).
- 6) KEYWAYS SHOWN ACROSS CORNERS OF SHAFT FOR DRAWING PURPOSES ONLY. KEYWAY ACTUAL LOCATION ACROSS FLATS.
- 7) (OPTIONAL) CHAMFER EACH SHAFT END 0.05 X 45°.